

CAPRI SQUARE - LISTE DES PIÈCES / PARTS LISTING

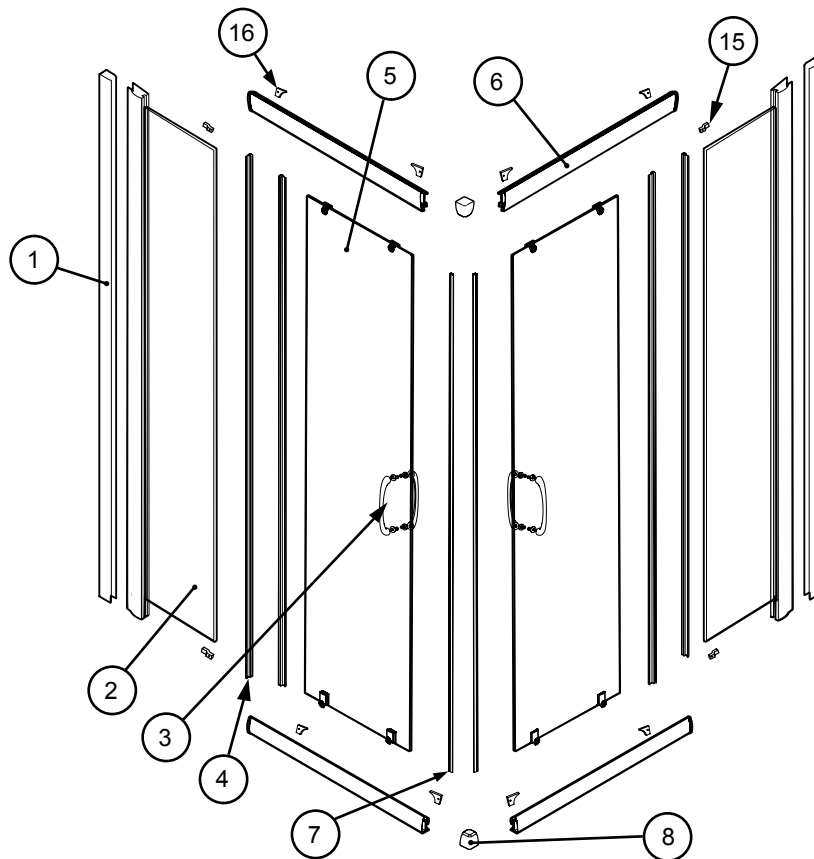

QUINCAILLERIE / HARDWARE

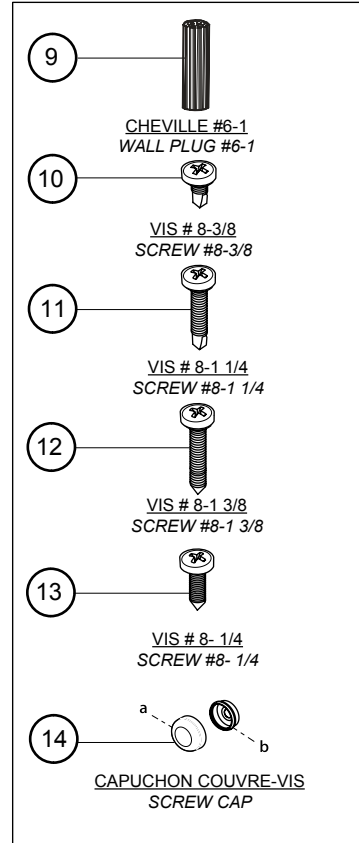

ITEM	PIÈCES - PARTS	DIMENSION (in)	QTY
1	JAMBAGE - WALL JAMB	72"	2
2P	ANNEAU FIXE AVEC EXTENSEUR - SIDE PANEL WITH EXPANDER		2
3P	OIGNÉE - HANDLE		2
4J	OINT LATÉRAL - SIDE GASKET	72"	4
5A	SSEMBLÉ DE PORTE - DOOR PANEL ASSEMBLY		2
6R	AIL SUPÉRIEUR ET INFÉRIEUR - TOP AND BOTTOM TRACK	31 9/16"	4
7J	OINT MAGNÉTIQUE - MAGNETIC DOOR GASKET	72"	2
8	ÉQUERRE DE COIN - CORNER CLIP		2
ITEM	QUINCAILLERIE - HARDWARE	DIMENSION (in)	QTY
9	CHEVILLE - WALL PLUG	# 6-19	
10	VIS AUTO-PERÇANTE - SELF DRILLING SCREW	3/8"	8
11	VIS AUTO-PERÇANTE - SELF DRILLING SCREW	1 1/4"	8
12	VIS - SCREW	1 3/8"	8
13	VIS - SCREW	1/4"	12
14	CAPUCHON COUVRE-VIS - SCREW CAP		9
15	SUPPORT DE VERRE - GLASS SUPPORT		4
16	BUTÉE - BUMPER		4
17	ESPACEUR - SPACER		4